

PE UNION TEE

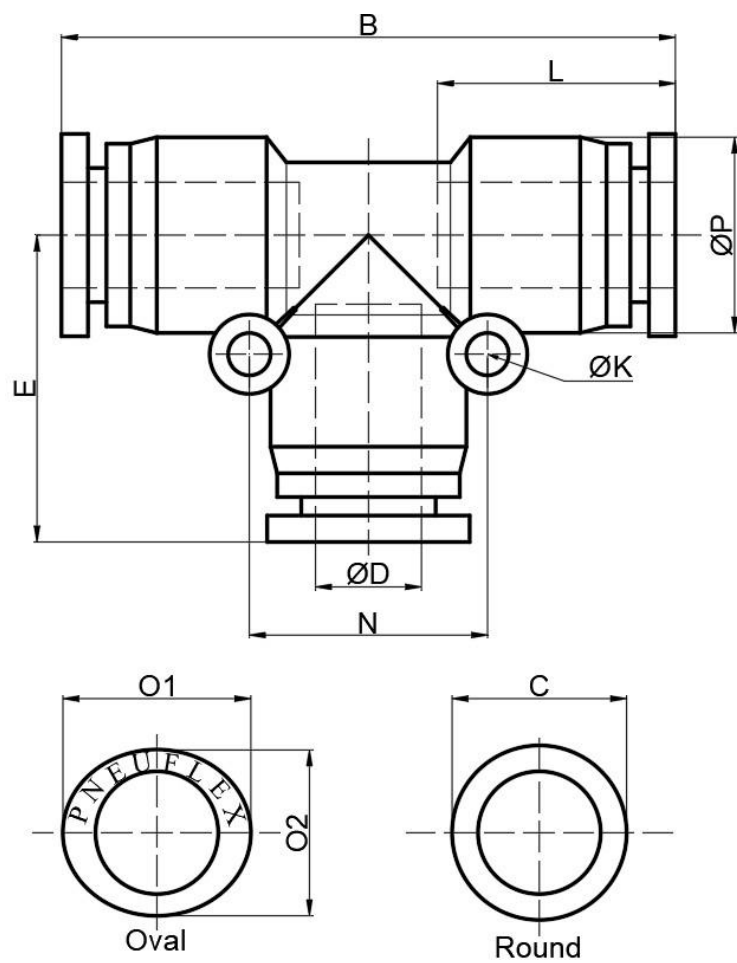

Model	Applicable Tubing ØD	ØP	B	L	E	N	ØK	O1	O2	C
PE 04	ø4mm	11	36	13.8	18.2	15	3.2	12	10.4	9.8
PE 05	ø5mm	13.5	38.8	15.9	19.4	16	3.2	13.8	12.4	11.8
PE 06	ø6mm	13.5	38.8	15.9	19.4	16	3.2	13.8	12.4	11.8
PE 07	ø7mm	15	46	19	23	18	3.2	16	13.8	13.8
PE 08	ø8mm	15	46	19	23	18	3.2	16	13.8	13.8
PE 09	ø9mm	19	56.6	21.8	28.3	24	4.2	19.5	17	16.8
PE 10	ø10mm	19	56.6	21.8	28.3	24	4.2	19.5	17	16.8
PE 11	ø11mm	21	59	22.8	29.5	27	4.2	23	20.5	19.8
PE 12	ø12mm	21	59	22.8	29.5	27	4.2	23	20.5	19.8
PE 14	ø14mm	23	64	24	32	31	5.3	25	22	21.8
PE 15	ø15mm	26	64.4	24	32.2	31	5.3	26.5	24.5	23.8
PE 16	ø16mm	26	64.4	24	32.2	31	5.3	26.5	24.5	23.8
PE 1/8	ø1/8"	11	36	13.8	18.2	15	3.2	12	10.4	9.8
PE 5/32	ø5/32"	11	36	13.8	18.2	15	3.2	12	10.4	9.8
PE 3/16	ø3/16"	11	36	14.3	18.2	15	3.2	12	10.4	9.8
PE 1/4	ø1/4"	13.5	38.8	15.9	19.4	16	3.2	13.8	12.4	11.8
PE 5/16	ø5/16"	15	46	19	23	18	3.2	16	13.8	13.8
PE 3/8	ø3/8"	19	56.6	22.3	28.3	24	4.2	19.5	17	16.8
PE 1/2	ø1/2"	21	59	22.8	29.5	27	4.2	23	20.5	19.8
PE 5/8	ø5/8"	26	64.4	24	32.2	31	5.3	26.5	24.5	23.8